

UTEC[®] *Automatic Sprinkler*

Ut0003, Ut0004 — Upright Sprinklers

Standard & Quick Response, Standard Coverage,

K-FACTOR: 5.6

DESCRIPTION

The UTEC[®] Series Ut0003, with the K-factor 5.6, is Standard Response sprinklers which utilize a 5mm frangible glass bulb, while the Ut0004 is Quick Response sprinkler with a 3mm glass bulb serving as the thermosensitive operating element. They are Listed and Approved as Standard Coverage sprinklers and are to be installed in accordance with the guidelines of the appropriate Installation Standard being mandated by the AHJ (i.e. NFPA 13; FM 2000). These sprinklers are available in various response sensitivity, temperatures and finishes as shown.



BRASS



CHROME



WHITE

LISTINGS AND APPROVALS

- cULus LISTED:



- FM APPROVED:



OPERATION

When a fire occurs and heat is absorbed, the thermal-sensitive liquid within the bulb expands and the internal pressure increases. When the internal pressure exceeds the strength of the glass, the glass would shatter. This results in the water discharge, which strikes the deflector and form a spray pattern to control or extinguish the fire.

NOTE

The UTEC[®] Series Sprinkler must be installed and maintained in compliance with standards of NFPA.

TECHNICAL SPECIFICATION

Sprinkler Identification Number (SIN)	Ut0003 & Ut0004
Response	Standard & Quick
Temperature Rating / Color / Classification	135°F (57°C) / Orange / Ordinary 155°F (68°C) / Red / Ordinary 175°F (79°C) / Yellow / Intermediate 200°F (93°C) / Green / Intermediate 286°F (141°C) / Blue / High
Discharge Coefficient GPM / psi ^{1/2} (LPM/bar ^{1/2})	K=5.6 (80)
Nominal Thread Size	1/2" NPT / 1/2" BSPT
Max. Working Pressure	175 PSI (12BAR)
Factory Testing Pressure	500 PSI (35BAR)
Min. Operating Pressure	7 PSI (0.5 BAR)
Finishes	Brass, White Coating and Chrome

SPRINKLER MATERIALS

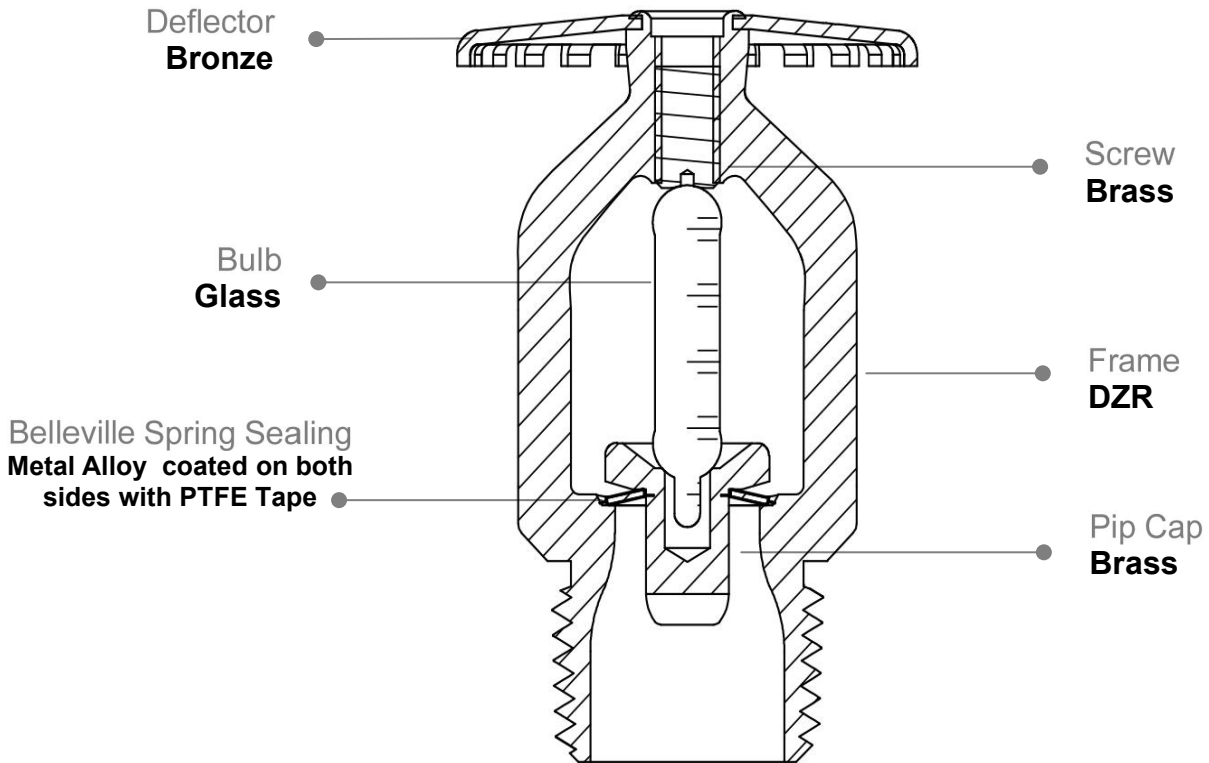

UPRIGHT SPRINKLER DISTRIBUTION

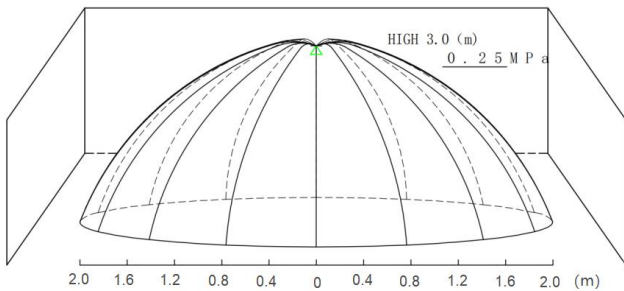

Protection Area (m²) : 12.0
Maximum Spacing (m) : 4.3

DISCHARGE COEFFICIENT

$$K = \frac{Q}{\sqrt{P}}$$

K-Factor

The coefficient of discharge, K, as expressed in the equation: Where Q is the flow in gallons per minute (gal/min), and P is the pressure in pounds per square inch (psi). Expressed in SI units: Q is the flow in liters per minute (L/min) and P is the pressure in bar. The discharge coefficient, therefore, has units of gal/min/(psi)^{1/2} or L/min/(bar)^{1/2}.

Flow Discharge Chart

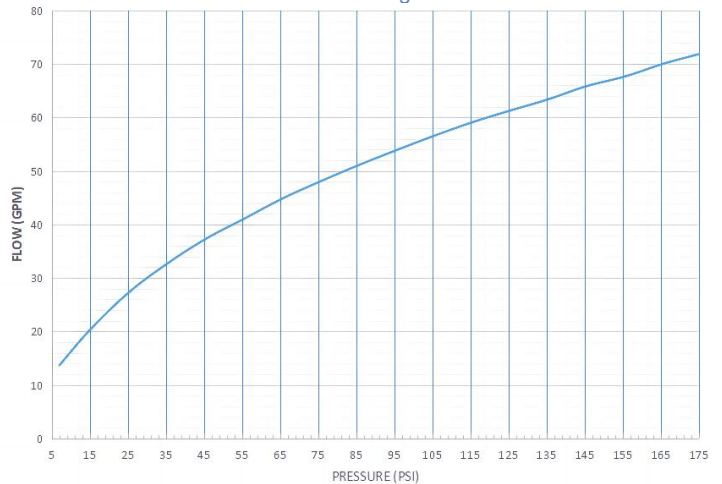

INSTALLATION METHODS

INSTRUCTION:

The Ut0003, Ut0004 sprinklers, which are manufactured and tested in accordance with the rigid requirements of the Standard UL 199, should also be installed in accordance with the latest edition of the Standard NFPA 13. The system piping must be properly sized to ensure the minimum required flow rate at the sprinkler. Check for the proper model, style, orifice size and temperature rating prior to installation, and install the sprinklers after the piping is in place. Pay attention to avoiding mechanical damage, and replace any damaged units. The wet pipe sprinkler systems must be protected from freezing. Upon completion of the installation, the system must be tested per recognized standard. In case of thread leakage, remove the unit, and apply new pipe jointing compounds or use the tape, and then re-install.

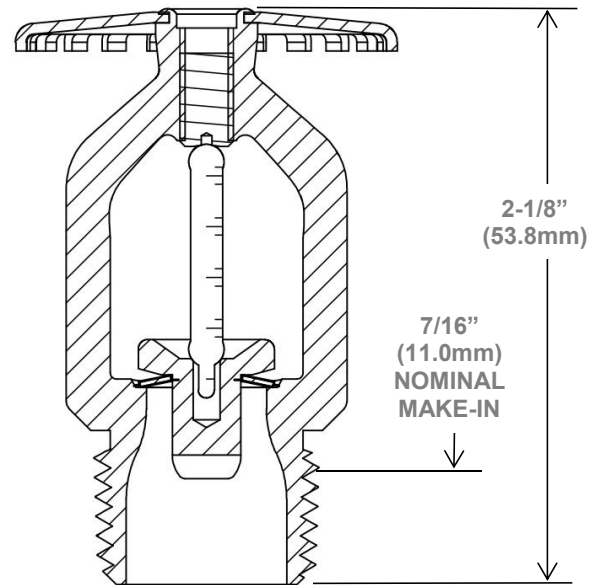

Upright Sprinkler Dimension

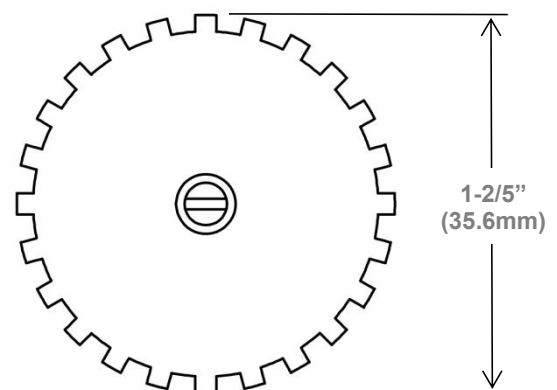

Upright Deflector Dimension

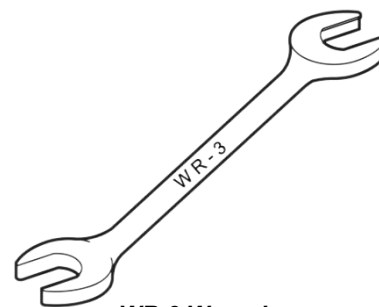

WR-3 Wrench

CAUTION

DO NOT INSTALL ANY SPRINKLER IF THE BULB IS CRACKED OR THERE IS A LOSS OF LIQUID FROM THE BULB!

METHOD:

- Step.1** The upright sprinkler is installed at upright position to suit field condition.
- Step.2** Only use the non-hardening pipe joint compound or Teflon tape for the male thread.
- Step.3** Hand-tighten the sprinkler into the fitting.
- Step.4** Tighten the sprinkler into the fitting using WR-3 wrench on flat. It is recommended that a torque of 7 ~14 ft-lbs be used to obtain a 1/2 inch NPT thread Sprinkler joint. Do not use wrench on the frame arms. It will cause the breakage of the arms and the burst of the glass bulb.

CAUTION

1. BE SURE TO REMOVE THE PLASTIC PROTECTION COVER AFTER INSTALLATION. DO NOT CLAMP IT ON THE FRAME ARMS, OTHERWISE WILL TO PREVENT THE HEAT RESPONSE FUNCTION WITH FAIL!
2. IT IS RECOMMENDED NOT TO EXCEED 14 FT-LB TORQUE FOR THE SPRINKLERS WITH 1/2 IN. NPT THREADS.
3. PROTECTIVE CAPS MUST BE REMOVED FROM SPRINKLERS BEFORE PLACING THE SYSTEM!